

Mining Excavator

R 9400

Operating Weight

Backhoe Configuration

345 tonnes / 380 tons

Face Shovel Configuration

353 tonnes / 389 tons

Engine Power

1,250 kW / 1,675 HP

Standard Bucket

Backhoe Configuration

24.0 m³ / 31.4 yd³

43.5 tonnes / 48.0 tons

Face Shovel Configuration

22.0 m³ / 28.8 yd³

40.0 tonnes / 44.0 tons



LIEBHERR



Productivity

Working Harder and Faster



Efficiency

Moving More for Less



Reliability

Ready to Work
When You Need It

Operating Weight

Backhoe Configuration

345 tonnes / 380 tons

Face Shovel Configuration

353 tonnes / 389 tons

Engine Power

1,250 kW / 1,675 HP

Standard Bucket

Backhoe Configuration

24.0 m³ / 31.4 yd³

43.5 tonnes / 48.0 tons

Face Shovel Configuration

22.0 m³ / 28.8 yd³

40.0 tonnes / 44.0 tons

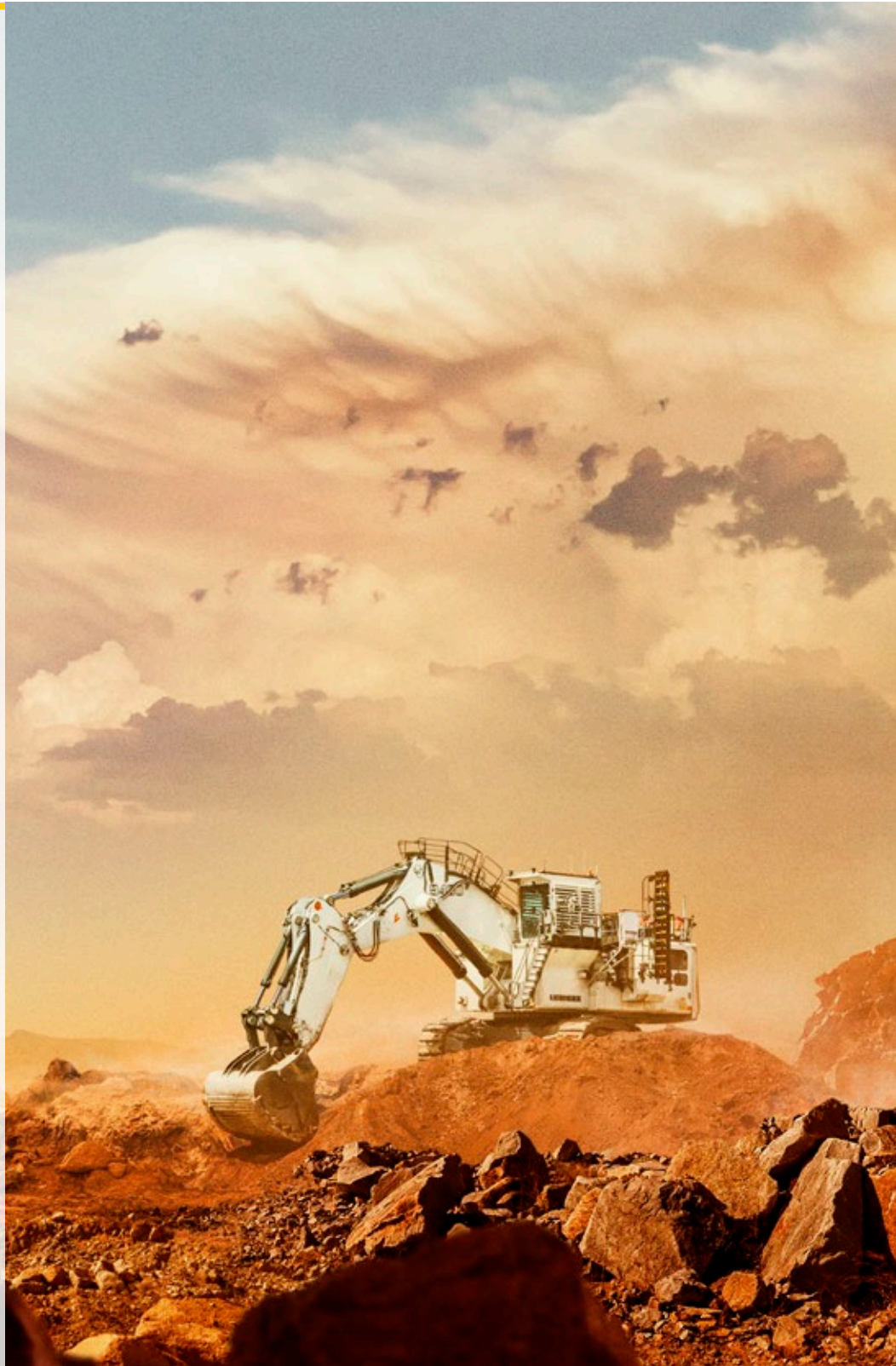



Customer Service

World-Class Support,
Everywhere, Every Day



Safety

Protecting Your Most
Important Assets



Environment

Mining Responsibly





Productivity



Working Harder and Faster

The R 9400 is built to outperform all competitors in the medium class mining market. Boasting a 24.0 m³/31.4 yd³ bucket capacity in standard configuration, the R 9400 is the ideal machine to load a fleet of 100 – 240 t mining trucks. Available in both diesel or electric versions, the R 9400 offers the flexibility to perform many specific applications.

Fast and Precise Movement

Powerful Drive System

The R 9400 is equipped with a Cummins diesel engine which has been specifically adapted to withstand the most extreme environments and to reach the highest uptime performance for maximum productivity. The electric drive system provides superior performance when the machine is used in the toughest of conditions.

Fast Cycle Time

Rather than using a standard open hydraulic circuit, the R 9400 employs a closed-loop swing circuit, enabling maximum swing torque while retaining the full oil flow for the working circuit. The independent swing circuit in combination with the powerful drive system leads to fast arm motion, contributing to faster cycle times.

Precise Machine Motions

The R 9400 design integrates the Litronic Plus electronic control system allowing for easy control even when simultaneous movements are required. The patented Liebherr electronic damping system provides controlled end-cushioning for smooth attachment motions.

High Digging and Lifting Capabilities

High Digging Forces

Designed for the best mechanical force distribution, the production-tailored attachment delivers increased digging and lifting forces. Integrating Liebherr-made cylinders and a wide range of buckets with mining-optimized GET, the R 9400's attachment ensures the highest forces, easy bucket penetration and high fill factor to perform even in the most demanding conditions.

Power-Oriented Energy Management

The R 9400's attachment is equipped with pressureless boom-down function to enable fast cylinder retraction without the need for pump energy. Intelligent energy management diverts the pump flow during boom lowering, allowing other cylinder motions to operate unimpeded.



Engine / Motor Options

Diesel engine:

- Cummins QSK 50
- US EPA Tier 2, US EPA Tier 4f / EU Stage V compliant
- Fuel consumption optimized version (optional)

Electric drive (optional):

- 3 phase AC squirrel cage motor
- Voltage on request
- 50 or 60 Hz frequency

Electronic Cylinder Damping System

- Patented system based on electronic control
- Controlled end-cushioning for smooth attachment motions
- Allows the operator to focus on loading
- Intelligent energy management
- Increase of cylinders reliability

High Performance Execution

An innovative attachment solution to improve cost per tonne, maximize machine productivity/truck utilization without any compromise in structural/component life and cycle time:

- Use of Smart Components Design to reduce total weight, increasing bucket payload and reinforcing bucket wear protection for extended lifetime
- Maximized loading capacity thanks to Liebherr Bucket Solution and patented EVO design



Efficiency



Moving More for Less

The R 9400 follows the Liebherr design philosophy of maximizing a machine's performance by improving the efficiency of all individual subsystems. Engineered for easy serviceability the machine is designed to ensure maximum uptime. The R 9400's spacious cab creates a comfortable working environment, ensuring peak operator performance at every shift.

Built for Maximum Profitability

Electro-Hydraulic System Efficiency

Liebherr hydraulic technology in combination with the precision of electronic control contributes to the R 9400's efficient use of energy. The high-pressure hydraulic system and the optimized pipe and hose layout maximize usable power transmission. Hydraulic pumps are electronically managed to provide optimal pressure compensation and oil flow management. The hydraulic system is independently regulated over the engine circuit for the best operational efficiency.

Independent Cooling System

Oil and water cooling fans are independent and electronically managed. The on-demand cooling control provides efficient power for the working process. This technology contributes to maintaining sustainable temperature of all hydraulic components, extending their life.

Closed Loop Swing Circuit

All Liebherr Mining excavators are equipped with a closed loop swing circuit. Kinetic energy can be saved when the swing motion is used during deceleration, to drive the main and auxiliary pumps, reducing fuel consumption and allowing faster boom lift motion.

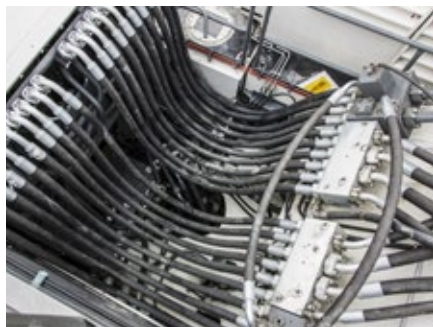

Hydraulic System Efficiency

The R 9400's hydraulic system is designed for an optimized hydraulic power management via the:

- Closed-loop swing circuit
- Pressureless boom down function
- Electronic hydraulic pumps management
- High pressure hydraulic oil filtration system
- Electro-hydraulic control system
- Optimized pipe and hose layout

Fast Maintenance System

The service flap is hydraulically actuated and accessible from the ground level allowing for fast maintenance:

- Hydraulic oil refill
- Engine oil refill and drainage
- Splitter box and swing gearbox oil exchange
- Attachment/swing ring bearing grease barrel refilling with filters
- Windshield washer water refilling
- Fast fuel refilling line

Comfort-Oriented Cab Design

- Tinted laminated safety glass
- Armored front and attachment side windows
- Heavy duty sun louvers on windows
- Adjustable air suspended seat
- A/C with dust filter in fresh air/recirculated
- Pressurization to prevent dust penetration
- Trainer's seat

Comfortable Cab for Efficient Work

Superior Operator Comfort

The large and spacious cab provides ideal working conditions and optimal operator's comfort. Mounted on silent blocks, the cab design reduces vibrations and limits noise pollution to provide a quiet working environment.

Extended Components Lifetime

The R 9400's high pressure hydraulic oil filtration systems remove contaminants from the fluid to offer the highest rate of hydraulic system efficiency. To maintain the oil quality, all return hydraulic oil flow goes through a 15/5 µm fine filtration system, while the grease and fuel tanks are sized to considerably extend the time between service intervals.



Reliability



Ready to Work When You Need It

With over 50 years of innovative thinking, engineering and manufacturing excellence, Liebherr sets the industry standard for advanced equipment design and technology tools to provide the most up-to-date product, responding to requirements of mining customers.

Quality: the Liebherr Trademark

Liebherr Components Integration

As an OEM, Liebherr has built a solid reputation for its development and production of high quality strategic mining components. The R 9400 integrates robust and reliable mining optimized components that are developed, manufactured and controlled by Liebherr ensuring reliable performance for the entire machine.

Machine Reliability Survey

Based on years of experience and the systematic measurement of key performance indicators of the machine behavior in the field, the Liebherr Mining Reliability Engineering Group is constantly seeking new ways to enhance reliability.

Quality Management Continuous Improvement

Liebherr quality begins during machine design and simulations. Liebherr meets the highest standards for special selections of steels and casting materials. Based on the expertise of certified internal auditors and a highly qualified workforce, all manufacturing process steps are devised to provide the most comprehensive control, monitoring and traceability. Liebherr-Mining Equipment Colmar SAS is ISO 9001 certified.

Long-lasting Job Performances

Maximized Component Lifetime

The R 9400 is equipped with an automatic single line lubrication system for the entire attachment and swing ring. All greasing points are suitably protected against external damages, extending component life and ensuring constant performance over the excavator's operational life.

Rugged Undercarriage Structure

The R 9400 is mounted on a heavy duty fatigue resistant undercarriage. The swing ring is reinforced to provide an improved superstructure weight distribution. Designed and built for both shovel and backhoe configurations, the enlarged undercarriage offers an efficient ground bearing pressure management providing the necessary stability and reliability.



Arctic Package (optional)

Designed for reliability in regions with temperatures of down to -50 °C / -58 °F:

- Integrated into machine structure
- Start up easily even at very low temperatures
- Increases machine availability and component lifetime
- Optimum operator comfort even in harsh temperature conditions
- Facilitate machine servicing

Strengthened Attachment Design

Backhoe or face shovel attachments are built to face all standard and specific applications:

- Use of advanced welding techniques
- Reinforced with strategically located castings in high stress areas
- Heat treatment to reduce residual stresses and increase fatigue life
- Designed for maximum structure life
- Use of cutting-edge engineering tools such as Finite Element Analysis and Fatigue Life Analysis

Quality Commitment

- Liebherr-Mining Equipment Colmar, France, ISO 9001 certified
- Compliance of materials tested in laboratory
- Quality control during the stages of production
- Vertical integration practice



Customer Service



Worldclass Support, Everywhere, Every Day

By partnering with our customers, Liebherr implements tailored solutions from technical support, spare parts and logistics solutions to global maintenance for all types of equipment, all over the world.

Customer Support

International Service Organization

The Liebherr Service Support has always been an important focus for the company. Complete service during all operating phases from machinery installation to problem solving, spare parts inventory and technical service. Our service team is close to our customers, delivering the best specific maintenance solution to reduce both equipment downtime and repair costs.

Complete Training Programs

The Liebherr Mining Training System provides blended training sessions for operator and maintenance staff to encourage productive, cost-effective and safe mining operation. The Liebherr Mining Training System employs online learning programs, factory and on-site sessions and simulator training.



Liebherr Service Tools

Liebherr delivers a wide range of service tools for excavator-specific maintenance ensuring optimal working conditions no matter the size of the component.

- An OEM-certified solution
- Maximized machine uptime
- Cost-efficient maintenance
- Easy machine serviceability
- Uncompromising operational safety

Remanufacturing

Reduced Costs and Investment

Over the course of a mining machine's lifetime, major components must be replaced to ensure continued safety, productivity and reliability. The Liebherr Mining Remanufacturing Program offers customers an OEM alternative to purchasing brand new replacement components. Enabling customers to achieve lowest possible equipment lifecycle costs without compromising quality, performance or reliability.

Fast Availability

A international service network and component facilities worldwide means that component repair services and exchange components are available to customers regardless of their location.



The Liebherr-Mining Remanufacturing Program

- Liebherr certified workshops
- As-new warranty
- OEM expertise
- Reduced costs and investment
- Fast availability

Genuine Parts

Performance

Using genuine Liebherr components ensures the best interaction within your machine, encouraging optimal performance and most effective machine operation. For all major components, Liebherr relies on its Liebherr Maintenance Management System to follow and monitor service life while predicting maintenance activities.

Partnership

Liebherr regularly reviews requirements for parts and components for individual machines, based on operating hours, consumption and planned maintenance, resulting in minimized downtime for customers. With access to the Global stock via all Liebherr Mining Warehouses, you will improve productivity by having the part you need, when you need it.



MyLiebherr Customer Portal

- Easy access parts online
- Available any time anywhere
- User friendly interface
- Online ordering
- Save time and money



Protecting Your Most Important Assets

The Liebherr R 9400 provides uncompromising safety for operators and maintenance crews. Equipped with the service flap accessible from the ground level and integrating wide open accesses, the R 9400 allows quick and safe maintenance. The R 9400's cab provides numerous features for operator safety.

Safety-First Working Conditions

Safe Service Access

The R 9400 is fitted with ergonomic access for fast and safe maintenance. All service points are within reach from one side and at machine level. The R 9400's upperstructure is accessible via a robust fixed ladder or via an optional hydraulic actuated 45° stairway.

Secure Maintenance

All components have been located to allow for effortless inspection and replacement. Numerous service lights are strategically located in the service areas to sustain suitable maintenance conditions, day or night. Emergency stops have been strategically placed in the cab, engine compartment and at ground level. The R 9400 eliminates hazards to ensure a safe environment for the service staff during maintenance.

Efficient Machine Protection

Protection Against Fire Ignition

The engine compartment integrates a bulkhead wall that separates the engine from the hydraulic pumps. This reduces the risk of hydraulic oil entering the engine compartment. The turbochargers and exhaust systems are heat shielded, and all the hydraulic hoses are made from a fire resistant material.

Automatic Fire Suppression System

The R 9400 can be equipped with a fully integrated fire suppression, employing a dual agent solution to prevent and protect the machine. The fire suppression system has both automatic and manual release capabilities, emergency stop devices are strategically located on the machine to be easily accessible in any case by the operator.



User Friendly Maintenance

The machine is easily visible even by night or in extremely dusty working environments thanks to:

- 12 long-range working LED lights located on attachment, uppercarriage and counterweight
- Travel alarm system with light and buzzer

Machine Access

Designed for safe access on the machine upperstructure via:

- A 45° powered stairway and catwalks with handrails and perforated steps
- Walkways with slip-resistant surfaces
- Emergency egress with handrails in front of the excavator

Commitment to Employees Safety

- Safe and protected access to the components
- Major components centralized to be easily accessible
- E-stops located for the operator and maintenance staff
- Ground-level fluid maintenance hub
- Rear and side vision system



Environment



Mining Responsibly

Liebherr considers the conservation and preservation of the environment as a major challenge for the present and future. Liebherr are considerate of environmental issues in designing, manufacturing and managing machine structures, providing solutions that allow customers to balance performance with environmental consciousness.

Minimized Impact on Life

Optimized Energy Consumption, Fewer Emissions

The intelligent energy management system facilitates interaction between the hydraulic system and engine output with the goal of maximum performance with minimum consumption. In "Eco-Mode" setting, the machine is set up to reduce engine load, significantly improve fuel consumption and reduce emissions.

Controlled Emission Rejection

The R 9400 is powered by a high horsepower diesel engine which complies with the US EPA Tier 2 or US EPA Tier 4f/EU Stage V emission limits. This power drive makes the R 9400 cost effective without compromising productivity and reduces the machines impact on the environment.

Sustainable Design and Manufacturing Process

Certified Environment Management Systems

Subject to the stringent European program for the regulation of the use of chemical substances in the manufacturing process (REACH*), Liebherr undertakes a global evaluation to minimize the impacts of hazardous material, pollution control, water conservation, energy and environmental campaigns.

Extended Components and Fluids Lifetime

Liebherr is constantly working on ways to extend component life. Through the Exchange Components program, superior lubrication systems and the reinforcement of parts under stress, Liebherr can reduce frequency of part replacement. The result minimizes environmental impact and lowers the overall total cost of ownership.

*REACH is the European Community Regulation on chemicals and their safe use (EC 1907/2006) It deals with the Registration, Evaluation, Authorization and Restriction of Chemical Substances.



The Liebherr-Mining Remanufacturing Program

- Second life for your components
- Liebherr certified workshops
- Reduced environmental impact
- Reduced costs and investment
- Alternative to purchase brand-new replacement components

Sound Attenuation Package (optional)

Developed with the latest noise measurement technologies, this approach is based on both removal of noise at the source and passive sound attenuation:

- Noise-optimized fan regulation
- Larger and additional mufflers with tail pipe absorbers
- Sound attenuation on louvers, doors and walls
- Additional high volume sound attenuation boxes

Electric Drive Version

The electric drive system is an efficient alternative to diesel engine allowing:

- Less vibration resulting in higher component lifetime
- Lower maintenance costs
- Less noise pollution
- High motor efficiency
- Maximum efficiency in cold climate conditions when combined with the Arctic Kit

Technical Data



Engine

1 Cummins diesel engine	
Rating per SAE J1995	1,250 kW (1,675 HP) at 1,800 rpm
Model	Cummins QSK50 (US EPA Tier 2, US EPA Tier 4f/EU Stage V compliant or fuel consumption optimized setting)
Type	16 cylinder turbocharged V-engine after-cooler separate water cooling circuits common-rail
Bore/Stroke	159/159 mm / 6.26/6.26 in
Displacement	50.3 l/3,069 in ³
Engine cooling system	fans driven via hydraulic piston motor
Air cleaner	dry-type air cleaner with pre-cleaner, with automatic dust ejector, primary and safety elements
Fuel tank	6,908 l/1,825 gal
Electrical system	
Voltage	24 V
Batteries	4 x 180 Ah/12 V service systems
Alternator	24 V/260 Amp
Engine idling	automatic engine idling
Electronic engine power management	engine power and speed sensing over the entire engine rpm range



Electric Motor (optional)

1 electric motor	
Power output	1,350 kW (1,810 HP)
Type	3-phase AC squirrel cage motor
Voltage	6,000 V, other voltage on request
Frequency	50 Hz (or 60 Hz)
Revolutions	1,500 rpm or 1,800 rpm
Motor cooling	integrated air-to-air heat exchanger
Starting method	inrush current limited to 2.2 full load current



Electro-Hydraulic Controls

Servo circuit	independent, electric over hydraulic proportional controls of each function
Emergency control	via accumulator for all attachment functions with stopped engine
Power distribution	via monoblock control valves with integrated primary relief valves and flanged on secondary valves
Flow summation	attachment and travel drive
Control functions	
Attachment and swing	proportional via joystick levers
Travel	proportional via foot pedals or hand levers
Bottom dump bucket	proportional via foot pedals



Swing Drive

Hydraulic motor	2 Liebherr axial piston motors
Swing gear	2 Liebherr planetary reduction gears
Swing ring	Liebherr, sealed triple roller swing ring, internal teeth
Swing speed	0 – 3.9 rpm
Swing-holding brake	hydraulically released, maintenance-free, multi-disc brakes integrated in each swing gear



Hydraulic System

Hydraulic pump	
for attachment and travel drive	4 variable flow axial piston pumps
Max. flow	4 x 751 l/min./4 x 198 gpm
Max. pressure	320 bar/4,640 psi
for swing drive	2 reversible swashplate pumps, closed-loop circuit
Max. flow	2 x 390 l/min./2 x 103 gpm
Max. pressure	350 bar/5,076 psi
Pump management	electronically controlled pressure and flow management with oil flow optimisation
Hydraulic tank capacity	2,200 l/581 gal
Hydraulic system capacity	4,200 l/1,110 gal
Hydraulic oil filter	1 high pressure safety filter after each main pump + fine filtration of entire return flow (15/5 µm)
Hydraulic oil cooler	2 separate coolers, 2 temperature controlled fans driven via hydraulic piston motor



Electric System

Electric isolation	easy accessible battery isolations
Working lights	high brightness LED lights: – 4 on working attachment – 2 on cabin – 3 on RHS of uppercarriage – 3 on LHS of uppercarriage
Emergency stop switches	at ground level, in hydraulic compartment, in engine compartment, at valve bank and in operator cab
Electrical wiring	heavy duty execution in IP 65 standard for operating conditions of –50 °C to 100 °C/ –58 °F to 212 °F



Uppercarriage

Design	torque resistant designed upper frame in box-type construction for superior strength and durability
Attachment mounting	parallel longitudinal main girders in box section construction
Machine access	45° access system with handrails on the cab side of the uppercarriage, full controlled descent, in case of emergency stop additional emergency ladder fitted near the cab



Operator's Cab

Design	resiliently mounted, sound insulated, large windows for all around visibility, integrated falling object protection FOPS (ISO 10262)
Operator's seat	suspended, body-contoured with shock absorber, adjustable to operator's weight
Cabin windows	20.5 mm/0.8 in tinted armored glass for front window and 18 mm/0.7 in for right hand side windows, all other windows in tinted safety glass, high pressure windshield-washer system 75 l/20 gal watertank, aluminium sun louvers on all windows
Heating system/ Air conditioning	heavy duty, fully automatic, high output air conditioner and heater unit, contains fluorinated greenhouse gases HFC 134a with a Global Warming Potential (GWP) of 1430, the AC circuit contains 8.0 kg/ 17.6 lb of HFC-134 representing an equivalent of 11.4 tonnes/ 12.6 tons of CO ₂ , the 2 nd AC circuit (optional) contains 4.8 kg/ 10.6 lb of HFC-134 representing an equivalent of 6.9 tonnes/ 7.6 tons of CO ₂
Cabin pressurization	ventilation with filter, minimum pressurization of 50 Pa (ISO 10263-3)
Controls	joystick levers integrated into armrest of seat
Monitoring	via LCD-display, data memory
Rear vision system	camera installation on counterweight and right-hand side of the uppercarriage, displayed over an additional LCD-display
Automatic engine shut off	engine self-controlled power limitation and shut off
Destroking of main pumps	in case of low hydraulic oil level
Safety functions	additional gauges with constant display for: engine speed, hourmeter, voltmeter, safety mode for engine speed control and pump regulation
Noise level (ISO 6396)	Diesel: L _{pA} (inside cab) = 78 dB(A)



Undercarriage

Design	3-piece undercarriage, box-type structures for center piece and side frames (stress relieved steel work component as a standard)
Hydraulic motor	2 axial piston motors per side frame
Travel gear	Liebherr planetary reduction gear
Travel speed	0 – 2.7 km/h/0 – 1.67 mph
Parking brake	spring engaged, hydraulically pressure released external wet multi-disc brakes for each travel motor, maintenance-free
Track components	maintenance-free, forged double grouser pad, tractor-type chain, optional maintenance-free dual pin cast link and pad combined
Track rollers/ Carrier rollers	9/2 per side frame
Track tensioner	pressurized hydraulic cylinder with accumulator and grease adjuster
Transport	undercarriage side frames are removable



Service Flap

Design	hydraulically actuated service flap, with lighting easily accessible from ground level to allow: <ul style="list-style-type: none"> – fuel fast refill – hydraulic oil refill – engine oil quick change – splitterbox oil quick change – swing gearbox oil quick change – swing ring teeth grease barrel refilling via grease filter – attachment/ swing ring bearing grease barrel refilling via grease filter – windshield wash water refilling – other coupler type on request
---------------	--



Central Lubrication System

Type	single-line lubrication system, for the entire attachment/ swing ring bearing and teeth
Grease pumps	1 hydraulic grease pump for the attachment/ swing ring bearing and 1 hydraulic grease pump for swing ring teeth
Capacity	200 l/53 gal bulk container for attachment/ swing ring bearing, separated 80 l/21 gal bulk container for swing ring teeth
Refill	via the service flap for both containers, fill line with grease filters



Attachment

Design	box-type structure with large steel castings in all high-stress areas
Stick Pivots	wear protection underneath lower beam plate sealed with double side centering with 1 single floating pin per side, all bearings with wear resistant steel bushings, bolts hardened and chromium-plated
Hydraulic cylinder	Liebherr design and made, all cylinders located in well protected areas
Hydraulic connections	pipes and hoses equipped with SAE split-flange connections
Pivots bucket-to-stick Pivots bucket-to-link	O-ring sealed and completely enclosed
Lubrication	connected to the centralized lubrication system, each lubrication point independently lubricated
Kinematics	Liebherr parallel face shovel attachment geometry, backhoe bucket pivoting angle 150°, electronic controlled end-cushioning

Dimensions

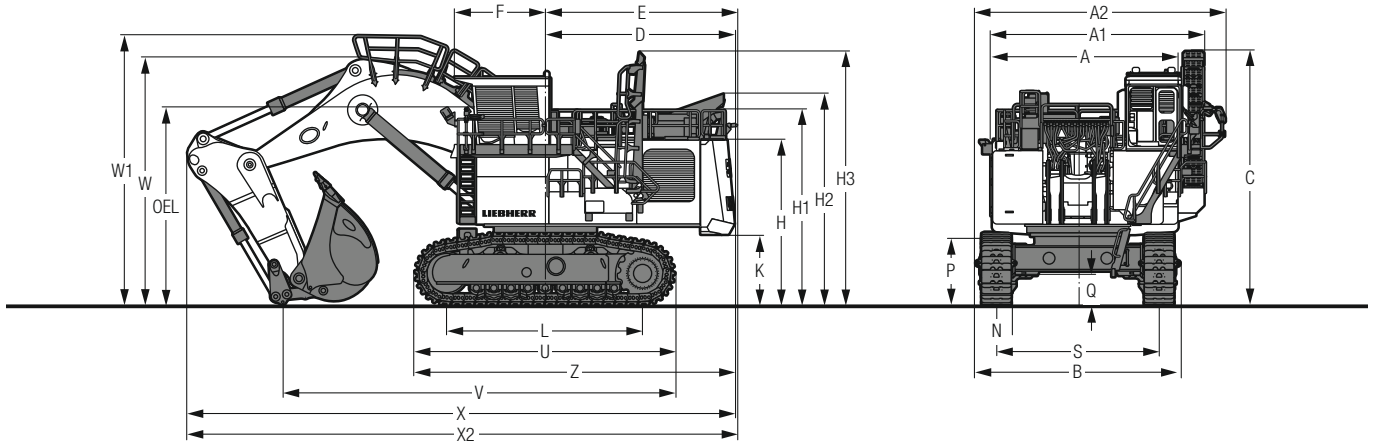

	mm/ft in
A	6,300/20' 8"
A1	8,350/27' 5"
A2	8,520/27'11"
B	6,930/22' 9"
C	8,045/26' 5"
D	6,400/20'11"
E	6,700/22'
F	3,090/10' 2"
H	5,615/18' 5"
H1	6,600/21' 8"
H2	7,175/23' 6"
H3	8,585/28' 2"
K	2,385/ 7'10"

	mm/ft in
L	6,645/21'10"
N	1,000/ 3' 3"
P	3,000/ 9'10"
Q	1,190/ 3'11"
S	5,520/18' 1"
U	8,800/28'10"
V	13,280/43' 7"
W	8,420/27' 7"
W1	9,250/30' 4"
X	18,530/60'10"
X2	18,630/61' 1"
Z	10,840/35' 7"
OEL	Operator's eye level 6,740/22' 1"

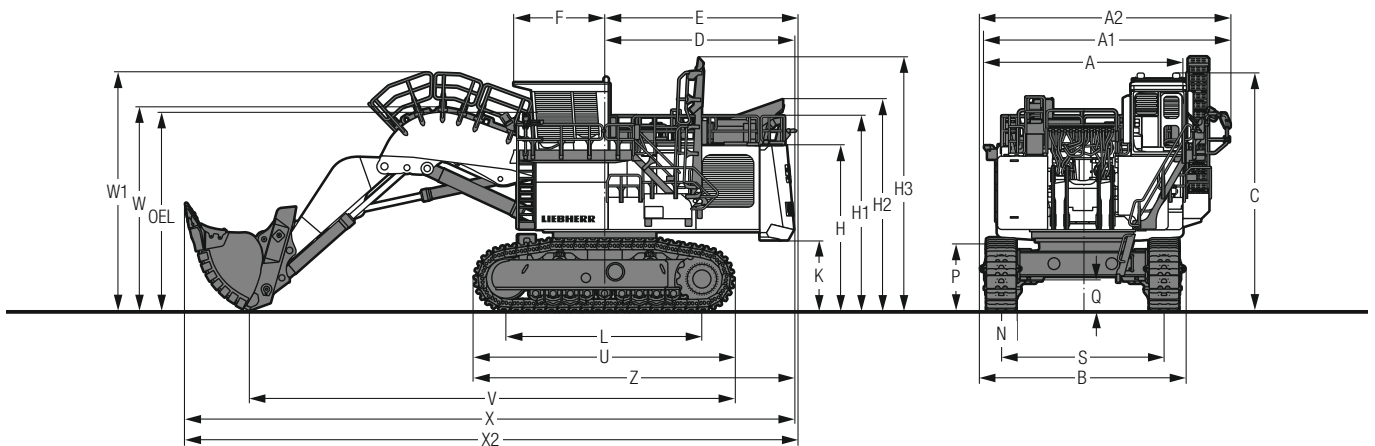

	mm/ft in
A	6,300/20' 8"
A1	8,350/27' 5"
A2	8,520/27'11"
B	6,930/22' 9"
C	8,045/26' 5"
D	6,400/20'11"
E	6,700/22'
F	3,090/10' 2"
H	5,615/18' 5"
H1	6,600/21' 8"
H2	7,175/23' 6"
H3	8,585/28' 2"
K	2,385/ 7'10"

	mm/ft in
L	6,645/21'10"
N	1,000/ 3' 3"
P	3,000/ 9'10"
Q	1,190/ 3'11"
S	5,520/18' 1"
U	8,800/28'10"
V	16,430/53'11"
W	6,930/22' 9"
W1	8,120/26' 8"
X	20,620/67' 8"
X2	20,720/68'
Z	10,840/35' 7"
OEL	Operator's eye level 6,740/22' 1"

Backhoe Attachment

with Mono Boom 9.30 m/30'6"

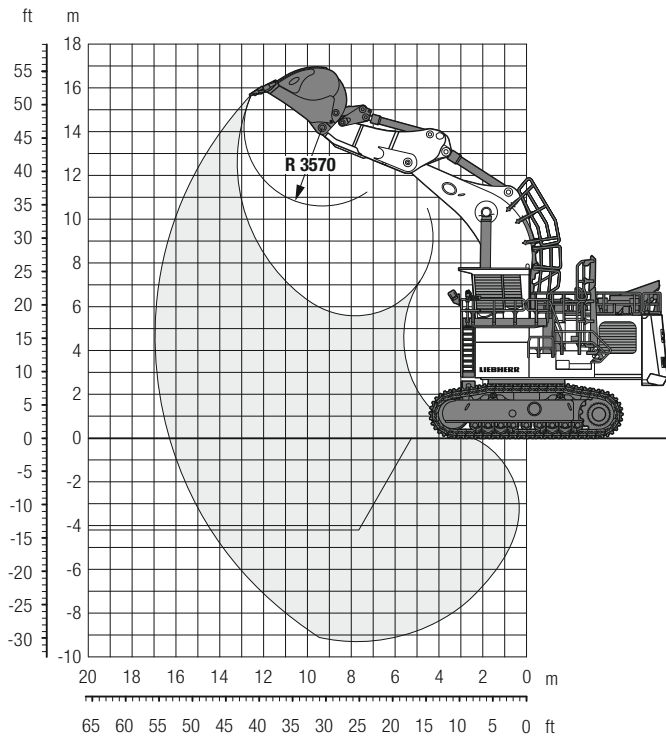

Digging Envelope

Stick length	m	4.20
	ft in	13'8"
Max. digging depth	m	9.30
	ft in	30'5"
Max. reach at ground level	m	16.30
	ft in	53'5"
Max. dumping height	m	10.60
	ft in	34'8"
Max. teeth height	m	15.70
	ft in	51'5"

Forces

Max. digging force (ISO 6015)	kN	965
	lbf	216,940
Max. breakout force (ISO 6015)	kN	1,000
	lbf	224,809

Operating Weight and Ground Pressure

The operating weight includes the basic machine with backhoe attachment and backhoe bucket
24.00 m³/31.4 yd³.

Pad width	mm / ft in	1,000 / 3'3"
Weight	kg / lb	345,500 / 760,600
Ground pressure*	kg/cm ² / psi	2.33 / 33.11

* according to ISO 16754

Backhoe Buckets

For materials class according to VOB, Section C, DIN 18300	< 5	5 – 6	5 – 6	5 – 6	7 – 8	7 – 8
Typical operation according to VOB Section C, DIN 18300	GP	HD	HD	HD	XHD	XHD
Capacity ISO 7451						
	m ³	26.00	20.00	24.00	26.00	20.70
	yd ³	34.0	26.2	31.4	34.0	27.1
Suitable for material up to a specific weight of						
	t/m ³	1.7	2.2	1.8	1.6	2.0
	lb/yd ³	2,867	3,710	3,035	2,698	3,373
Cutting width						
	mm	3,900	3,400	3,700	3,900	3,700
	ft in	12'9"	11'1"	12'1"	12'9"	12'1"
Weight						
	kg	20,500	20,700	21,500	22,300	23,000
	lb	45,195	45,636	47,400	49,163	50,706

GP: General purpose bucket with Liebherr Z140 teeth

HD: Heavy-duty bucket with Liebherr Z140 teeth

XHD: Heavy-duty rock bucket with Liebherr Z140 teeth

Face Shovel Attachment with Shovel Boom 6.75 m / 22'1"

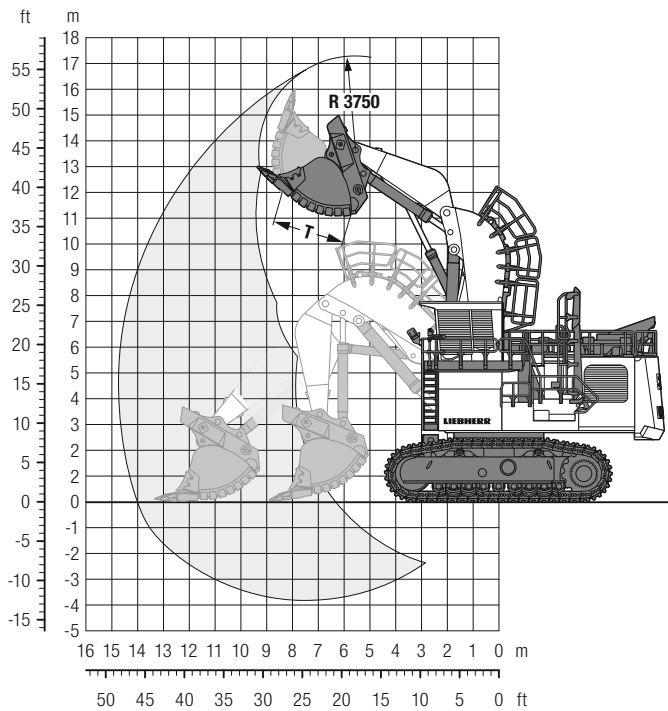

Digging Envelope

Stick length	m	4.30
	ft in	14'1"
Max. reach at ground level	m	14.00
	ft in	45'11"
Max. dumping height	m	11.20
	ft in	36'8"
Max. crowd length	m	4.50
	ft in	14'9"
Bucket opening width T	m	2.50
	ft in	8'2"

Forces

Max. crowd force at ground level (ISO 6015)	kN	1,145
	lbf	257,406
Max. crowd force (ISO 6015)	kN	1,545
	lbf	347,330
Max. breakout force (ISO 6015)	kN	1,195
	lbf	268,646

Operating Weight and Ground Pressure

The operating weight includes the basic machine with shovel attachment and bucket 22.00 m³/28.8 yd³.

Pad width	mm / ft in	1,000 / 3'3"
Weight	kg / lb	353,000 / 778,200
Ground pressure*	kg/cm ² / psi	2.38 / 33.83

* according to ISO 16754

Face Shovel Buckets

For materials class according to VOB, Section C, DIN 18300	< 5	< 5	5 – 6	5 – 6	7 – 8	7 – 8
Typical operation according to VOB Section C, DIN 18300	GP	GP	HD	HD	XHD	XHD
Capacity ISO 7546	m ³ 24.00	22.00	18.00	22.00	18.00	19.00
	yd ³ 31.4	28.8	23.5	28.8	23.5	24.9
Suitable for material up to a specific weight of	t/m ³ 1.6	1.8	2.2	1.8	2.1	1.9
	lb/yd ³ 2,698	3,035	3,710	3,035	3,541	3,204
Cutting width	mm 4,250	4,250	4,250	4,250	4,250	4,250
	ft in 13'11"	13'11"	13'11"	13'11"	13'11"	13'11"
Weight	kg 36,700	35,400	35,400	35,400	37,500	38,500
	lb 80,910	78,044	78,044	78,044	82,673	84,878

GP: General purpose bucket with Liebherr Z140 teeth

HD: Heavy-duty bucket with Liebherr Z140 teeth

XHD: Heavy-duty rock bucket

Optional Equipment

Undercarriage

Monoblock chain system
Undercarriage bottom cover
Rock protection for idler wheel

Uppercarriage

Banlaw fast fueling system
Fueling system with Multiflo Hydra-Flo®
Wiggins/Banlaw counter plugs for fuel/lube trucks
Slewing ring with 90° installation arrangement
Swing ring scrapers

Hydraulic System

Oil cooler inlet screens

Engine

Fuel consumption optimized engine version (non-certified)
Automatic engine shutdown timer (5 min.)
Cummins Eliminator™ kit

Operator's Cab

4-point seat belt
Additional back and side wipers
Double A/C system
Front protective grid
Sliding window
Auxiliary cab heating system

Attachment

Piston rod guard for bucket cylinder (BH)

Specific Solutions

Arctic package (−30 °C/−22 °F, −40 °C/−40 °F, −50 °C/−58 °F)
Sound attenuation package (until +40 °C/+104 °F)
High altitude package

Safety

Automatic fire suppression system

General

Maritime transport packaging

The Liebherr Group of Companies



Wide Product Range

The Liebherr Group is one of the largest construction equipment manufacturers in the world. Liebherr's high-value products and services enjoy a high reputation in many other fields. The wide range includes domestic appliances, aerospace and transportation systems, machine tools and maritime cranes.

Exceptional Customer Benefit

Every product line provides a complete range of models in many different versions. With both their technical excellence and acknowledged quality, Liebherr products offer a maximum of customer benefits in practical applications.

State-of-the-art Technology

To provide consistent, top quality products, Liebherr attaches great importance to each product area, its components and core technologies. Important modules and components are developed and manufactured in-house, for instance the entire drive and control technology for construction equipment.

Worldwide and Independent

Hans Liebherr founded the Liebherr family company in 1949. Since then, the family business has steadily grown to a group of more than 130 companies with nearly 44,000 employees located on all continents. The corporate headquarters of the Group is Liebherr-International AG in Bulle, Switzerland. The Liebherr family is the sole owner of the company.

www.liebherr.com